

PUNTO DI SALDATURA 3 PARTICOLARI
WELDING POINT ON 3 ELEMENTS

Tolleranza generale fori ± 0.15
General tolerance holes ± 0.15

unit : mm
european view

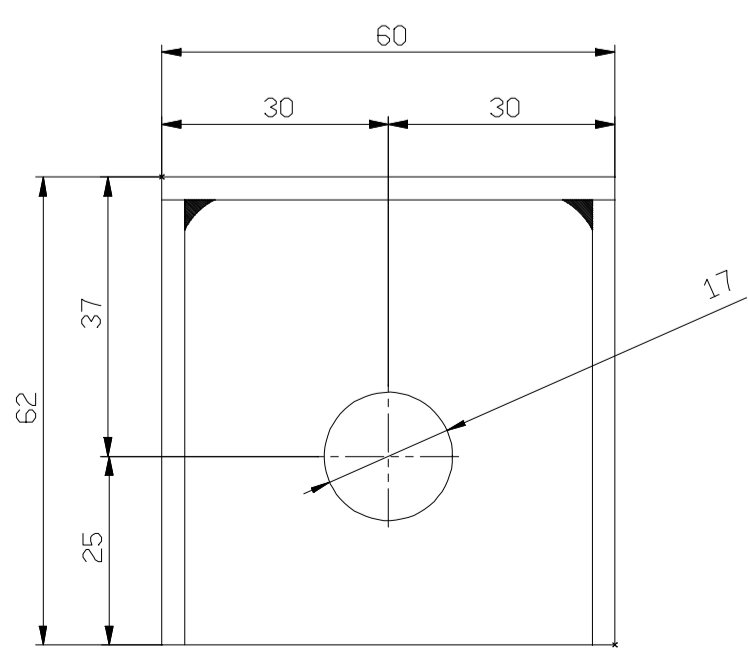

Tolleranze generali General tolerance	0 < . < 3	3 < . < 6	6 < . < 10	10 < . < 18	18 < . < 30	30 < . < 50	50 < . < 80	80 < . < 120	120 < . < 180	180 < . < 250	250 < . < 500	500 < . < 2000	
Lunghezze Lengths	± 0.15	± 0.20	± 0.25	± 0.30	± 0.35	± 0.40	± 0.50	± 0.60	± 0.70	± 0.80	± 1	/	
Angoli Angles	$0^\circ \leq . < 10^\circ$		$\pm 0.50^\circ$	$10^\circ \leq . < 45^\circ$		$\pm 1^\circ$	$45^\circ \leq . < 90^\circ$		$\pm 1.5^\circ$	$90^\circ \leq . < 360^\circ$			$\pm 2^\circ$

pos.	DESCRIZIONE DESCRIPTION	DIS. DESIGNER	APP. APPROVED	DATA DATE
	s.r.l. Via Monte Guglielmo, 61 25060 COGOZZO di Villa Carcina (Brescia) Italy Tel. +39 030 800916 - Fax + 39 030 802172 www.adveco.com	APP. CHECK.	MORETTI P.	DATA
		DIS. DESIGNER	L.L.	DATE 12-05-2016
	DENOMINAZIONE: ANGOLO PER FORZE DI TRAZIONE SQHT 440	SCALE		
	DENOMINATION: ANGLE BRACKET FOR TENSILE LOADS SQHT 440	DIS. N° DRAWING NR.	02SQHT440GR	REV. 0
	PESO 100 PEZZI TOLL. 10% WEIGHT 100 PIECES TOLL 10%	LAV. ZINCATURA MIN. 12 MATERIALE ACCIAIO S355 STEEL S355	TREATMENT ZINC COATING MIN. 12	

E' VIETATA LA RIPRODUZIONE ANCHE PARZIALE DEL PRESENTE DISEGNO SENZA L'AUTORIZZAZIONE DI ADVECO s.r.l.
IT IS FORBIDDEN THE REPRODUCTION, PARTIAL TOO, OF THIS DRAWING WITHOUT THE ADVECO WRITTEN AUTHORIZATION